

TCM 3100 Series Coriolis Mass Flow Meter

Advantages:

- > Robust for long life
- > Customized installation length
- > Excellent repeatability
- > Option for 345 bar (5000 psi)

Benefits:

- > Increased productivity
- > Considerable cost savings for installation
- > Increased product quality
- > Accurate chemical injection metering

Pressure Rating: 200 bar, 2900 psi

Specifications:

Mass Flow Rate (max.): 3100 kg/h, 114 lb/min
 Volumetric Flow Rate (max.): 3100 l/h, 13.19 gpm, 467 bbl/d
 Nominal Meter Size: DN6, 1/4"

Accuracy [liquids]:¹⁾

Basic Accuracy [Mass Flow]: ± 0.1 % of flow rate
 Mass Flow Repeatability: ± 0.05 % of flow rate
 Basic Accuracy [Volume Flow]: ± 0.15 % of flow rate
 Volume Flow Repeatability: ± 0.05 % of flow rate
 Zero Stability: ± 0.01 % of full scale

Accuracy [gases]:

Basic Accuracy [Mass Flow]: ± 0.5 % of flow rate
 Mass Flow Repeatability: ± 0.25 % of flow rate

Density:

Density Range: up to 2500 kg/m³, 2.5 g/cm³
 Density Accuracy: Liquids ± 1.0 kg/m³, ± 0.001 g/cm³
 Density Repeatability: ± 0.5 kg/m³, ± 0.0005 g/cm³

Temperature:

Process Temperature Range: Standard: -40 °F ... +212 °F (-40 °C ... +100 °C)
 Optional: -76 °F ... +392 °F (-60 °C ... +200 °C)
 Temperature Accuracy: ± 1.8 °F ± 0.5 % of reading
 (± 1 °C ± 0.5 % of reading)
 Temperature Repeatability: ± 0.36 °F (± 0.2 °C)

Materials of Construction [wetted parts]:

Tubes: 1.4404/AISI 316L
 Case: 1.4404/AISI 316L
 Flow Splitter: 1.4404/AISI 316L
 Brazing Alloy: BNI-2

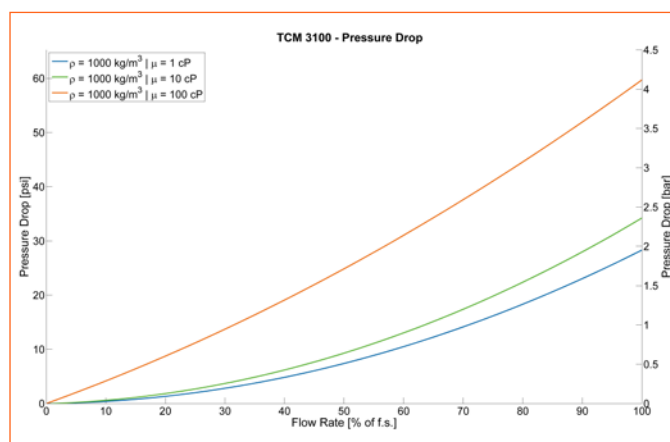

¹⁾ Stated flow accuracy combines the effects of repeatability, linearity and hysteresis.

Meter Dimensions:²⁾

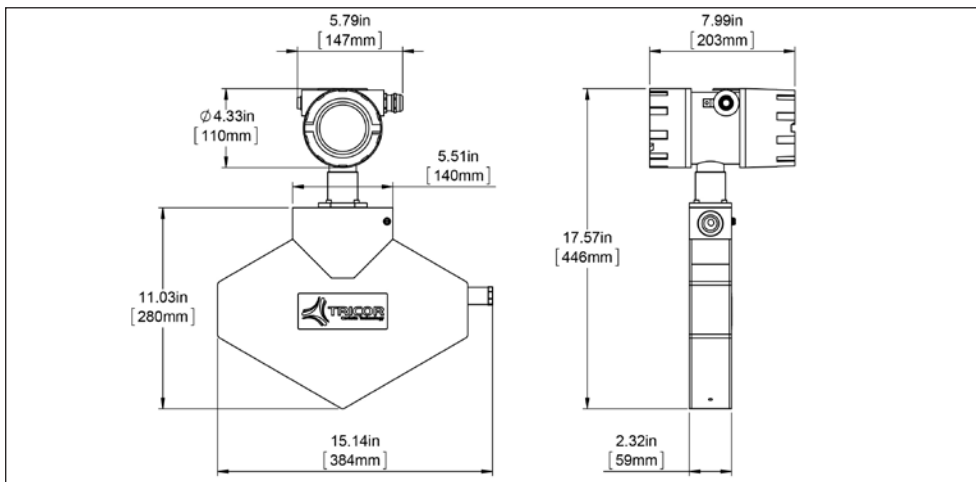

Compact Version

weight: 11.6 kg/25.7 lb
with meter mount ex-electronics
with aluminum diecast housing
meter connection: G1/2" thread

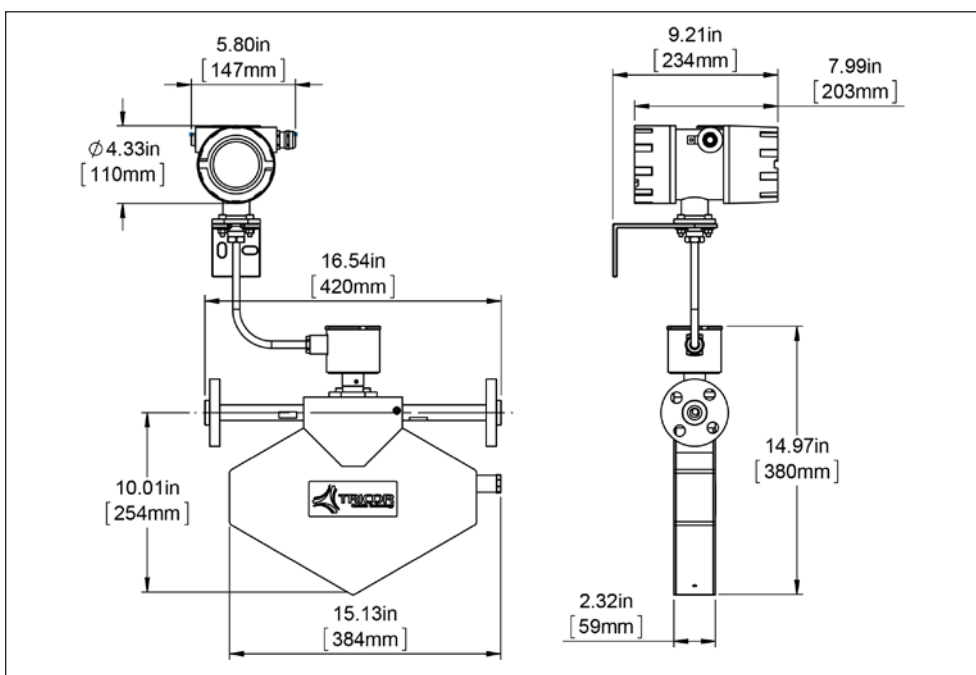

Remote Version

weight: 12.9 kg/28.5 lb
with junction box & remote field mount
meter connection:
depending on selected connection

Electronics:

The TCE-8000 transmitter offered with the TRICOR Coriolis Mass Flow Meter is also available with other mounting options.

Ex Certifications:

ATEX (Ex)	Zone 1: Group IIC or IIB, T2...T4
ATEX (Exn)	Zone 2: II 3G Ex nA IIC T2...T4 Gc
IECEX (Ex)	Zone 1: Group IIC or IIB, T2...T4
cCSAus (Ex1) ⁵⁾	Class 1, Division 1: Group A, B, C, D or C, D, T2...T4
ATEX + IECEX + cCSAus triple approval (Ex3) ⁵⁾ ⁶⁾	Zone 1: Group IIC or IIB, T2...T4 and Class 1, Division 1: Group A, B, C, D or C, D, T2...T4
EAC (TR-CU) ⁵⁾	Group IIC or IIB, T2 ... T4

Panel Mount³⁾



Power Supply:
Outputs:
Interface:
More options on request

Remote Field Mount⁴⁾



24 V DC $\pm 20\%$ or 90 ... 264 V AC
Analog, Frequency, Pulse, Status
RS485 RTU (Modbus), HART®

²⁾ Drawing of the Meter Dimensions reflects one standard connection, other connections on request (Installation length can vary depending on selected connection).

³⁾ Weight: 0.4 kg/0.88 lb.

⁴⁾ Weight with aluminum diecast housing: 3.8 kg/8.3 lb with 3 m cable, Weight with 1.4404/AISI 316L housing: 6.15 kg/13.56 lb.

⁵⁾ For Ex1, Ex3, EAC (TR-CU) the electronic is only available in aluminum housing.

⁶⁾ Only with remote electronics.



www.tricorflow.com

N & S AMERICA:

AW-Lake Company
2440 W. Corporate Preserve Dr. #600, Oak Creek WI 53154, USA, Tel.: +1 414 574 4300

SINGAPORE:

TASI Flow Souteast Asia, Representative Office (RO) Singapore
1003 Bukit Merah Central #06-32, Singapore 159836, UEN: T15RF0080G, P: +65 6274 1130

CHINA:

TASI Flow China
Rm. 2429, JinYuan Office Building, No. 36, CN- BeiYuan Road, Beijing 100012, P.R. CHINA, Tel.:+86 10 520 037 38

Rest of the World:

KEM Küppers Elektromechanik GmbH, Liebigstraße 5, 85757 Karlsfeld, Germany, Tel.:+49 8131 59391-0