

Turbine meters of the Vision series
For low viscous and non-aggressive liquids



Features

- Excellent price – performance ratio
- Small size
- Easy and fast installation
- Maintenance free
- High operating pressure
- Installation in any position

Description

The liquid turbine meters of the series Vision are for the exact measuring of small quantities of liquids. The actual flow as well as the already passed flow can be measured.

The large number of pulses gives a good resolution. As the mass of the turbine are very small the response time is very short. It is not necessary to install a straight length of pipeline at the upstream side. The simple mechanical construction of the sensor Vision guarantees a long lifespan without any loss of accuracy. Pressure surges do not affect the measuring system.

Measuring principle

The rotor is turned by the fluid force in proportional to the flow. A hall generator supplies pulses, which can be utilized for digital or analogue signal processing. The generated pulses are specified as the k-factor.

Applications

For flow measurement of water, demineralized water, alkaline solutions, oils/edible oils, fuel/fuel consumption, fuel oil, beverage, water based liquids, etc.

Special for washmachines, dish washers, coffee machines, laser cooling plants, solar solutions, bakery machines, steam cooking machines in large kitchen plants, dialysis equipment, CD cleaning, irrigation plants, etc.

Electrical connections



Technical data

Type	1005 2F66	2006 2F66	2006 4F44	2008 2F66
Material	Trogamid			
Connection*	G 1/4"		G 3/8"	
Order code (with coupler socket acc. EN 60529)	56547-163-2F66	56510-163-2F66	56510-163-4F44	56500-163-2F66
Order code for AMP Faston	-	56510-164-2F66	56510-164-4F44	56500-164-2F66
Order code for 1m-cable	56547-165-2F66-1	56510-165-2F66-1	56510-165-4F44-1	56500-165-2F66-1
Measuring rate l/min	0,1 – 2,5	0,5 - 5	1 – 10	0,5 – 7,5
K-factor PPL	22.000	6900	3300	4700
DN mm	5	6	6	8
Type	2008 4F44	2008 4F22	2008 4F17	3012 4F16
Material	Trogamid			
Connection*	G 3/8"			G 3/4"
Order code (with coupler socket acc. EN 60529)	56500-163-4F44	56500-163-4F22	56500-163-4F17	56422-163-4F16
Order code for AMP Faston	56500-164-4F44	56500-164-4F22	56500-164-4F17	-
Order code for 1m-cable	56500-165-4F44-1	56500-165-4F22-1	56500-165-4F17-1	56422-165-4F16-1
Measuring rate l/min	1 - 15	1 – 25	2 – 35	5 – 65
K-factor PPL	2200	1000	750	210
DN mm	8	8	8	12

Type	1005 2F66	2006 2F66	2006 4F44	2008 2F66
Material	Trogamid			
Connection*	NPT 1/4"		NPT 3/8"	
Order code (with coupler socket acc. EN 60529)	56548-163-2F66	56512-163-2F66	56512-163-4F44	56502-163-2F66
Article n° (AMP-Faston)	-	56512-164-2F66	56512-164-4F44	56502-164-2F66
Order code for 1m-cable	56548-165-2F66-1	56512-165-2F66-1	56512-165-4F44-1	56502-165-2F66-1
Measuring rate l/min	0,1 – 2,5	0,5 - 5	1 – 10	0,5 – 7,5
K-factor PPL	22.000	6900	3300	4700
DN mm	5	6	6	8
Type	2008 4F44	2008 4F22	2008 4F17	3012 4F16
Material	Trogamid			
Connection*	NPT 3/8"			NPT 3/4"
Order code (with coupler socket acc. EN 60529)	56502-163-4F44	56502-163-4F22	56502-163-4F17	56423-163-4F16
Order code (AMP-Faston)	56502-164-4F44	56502-164-4F22	56502-164-4F17	-
Order code (with 1m cable)	56502-165-4F44-1	56502-165-4F22-1	56502-165-4F17-1	56423-165-4F16
Measuring rate l/min	1 - 15	1 – 25	2 – 35	5 – 65
K-factor PPL	2200	1000	750	210
DN mm	8	8	8	12

*Other connections: O-ring; Hose nipple for Vision 2000

Type	1005 2F66	2006 2F66	2006 4F44	2008 2F66
Material	Brass			
Connection	-	-	-	G 3/8"
Order code (with coupler socket acc. EN 60529)	-	-	-	47000-163-2F66
Connection	-	-	-	NPT 3/8"
Order code (with coupler socket acc. EN 60529)	-	-	-	47001-163-2F66
Measuring rate l/min	-	-	-	2 - 8
K-factor PPL	-	-	-	4200
DN mm	-	-	-	8
Type	2008 4F44	2008 4F22	2008 4F17	3012 4F16
Material	Brass			
Connection	-	G 3/8"	-	-
Order code (with coupler socket acc. EN 60529)	-	47000-163-4F22	-	-
Connection	-	NPT 3/8"	-	-
Order code (with coupler socket acc. EN 60529)	-	47001-163-4F22	-	-
Measuring rate l/min	-	3 - 25	-	-
K-factor PPL	-	1000	-	-
DN mm	-	8	-	-

Type	1005 2F66	2006 2F66	2006 4F44	2008 2F66	2008 4F44	2008 4F22	2008 4F17	3012 4F16
Measuring rate l/min	0.1 – 2.5	0,5 – 5	1 – 10	0,50 – 7,5	1 – 15	1 – 25	2 – 35	5 – 65
K-factor PPL*	22.000	6900	3300	4700	2200	1000	750	210
Size mm	5	6	6	8	8	8	8	12
Viscosity range	0.8 - 16 mm ² /sec (mpas)							
Accuracy	+/- 3% of value							
Repeatability	Better than 0.5%							
Temperature range	-20 up to +100 °C							
Operating pressure	25 bar max							
Burst pressure	200 bar							~ 100 bar
Electrical connection **	- AMP Faston 2.8/6.3 x 0.8 mm - Connection MICRO-EN 60529 and 3 flat plugs 2.8 x 0.5 mm (point plate) - Cable connection: round cable 3xAWG 24 with free cable end							
Filter	20 to 40 micron recommended							
Power supply	5 - 24 VDC.							
Current consumption	Ca. 8 mA.							
Output signal	Pulses by open collector (NPN sinking).							
Output current	Max. 20 mA.							
Pull-up resistor	1 - 2.2 kOhm							
* PPL = Pulses per liter								
** DIN connector MICRO EN60529								

Pressure drop in bar for water (at 20 °C)

Type	1005 2F 66	2006 2F66	2006 4F44	2008 2F66	2008 4F44	2008 4F22	2008 4F17	3012 4F16
0,5 l / min	0.02	--	--	--	--	--	--	--
1 l / min	0.05	~ 0	~ 0	~ 0	~ 0	~ 0	~ 0	--
1,5 l / min	0.15	--	--	--	--	--	--	--
2 l / min	0.25 *	~ 0	0.06	~ 0	0.05	~ 0	~ 0	--
5 l / min	--	0.12	0.2	0.05	0.2	0.05	~ 0	0,00
10 l / min	--	0.4	0.7	0.2	0.4	0.17	~ 0.12	0,01
15 l / min	--	0.9	--	0.4	--	0.27	~ 0.25	0,02
20 l / min	--	1.3	--	0.7	--	0.48	~ 0.45	0,05
25 l / min	--	--	--	--	--	0.65	~ 0.60	0,07
30 l / min	--	--	--	--	--	--	~ 0.92	0,11
35 l / min	--	--	--	--	--	--	--	0,14
40 l / min	--	--	--	--	--	--	--	0,18
45 l / min	--	--	--	--	--	--	--	0,23
50 l / min	--	--	--	--	--	--	--	0,28
55 l / min	--	--	--	--	--	--	--	0,34
60 l / min	--	--	--	--	--	--	--	0,40
65 l / min	--	--	--	--	--	--	--	0,47

* Value applies to 2.5 l/min

Display operation

Electr. connection	Coil for battery powered display required
Supply	2 – 5,5 VDC
Power consumption	Approx. 2,2 mA @ 2V
Output signal	Push - Pull
Output current	Max. 30 mA

Dimensions (in mm)

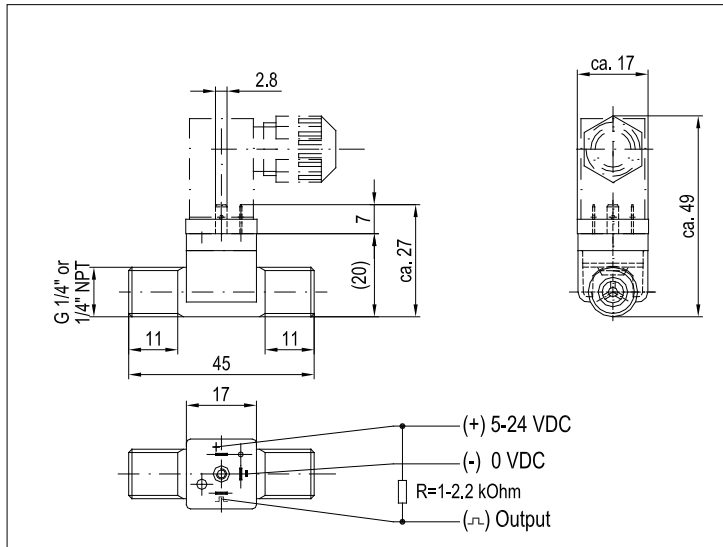

Example: Vision 1000 with DIN plug

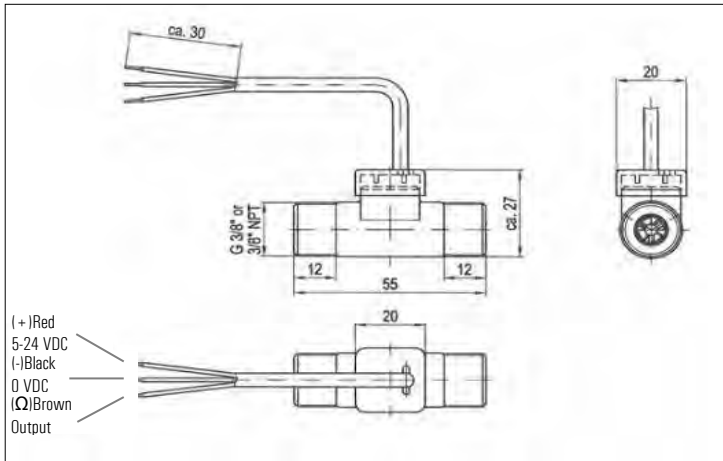

Example: Vision 2000 with round cable 3 x AWG 24

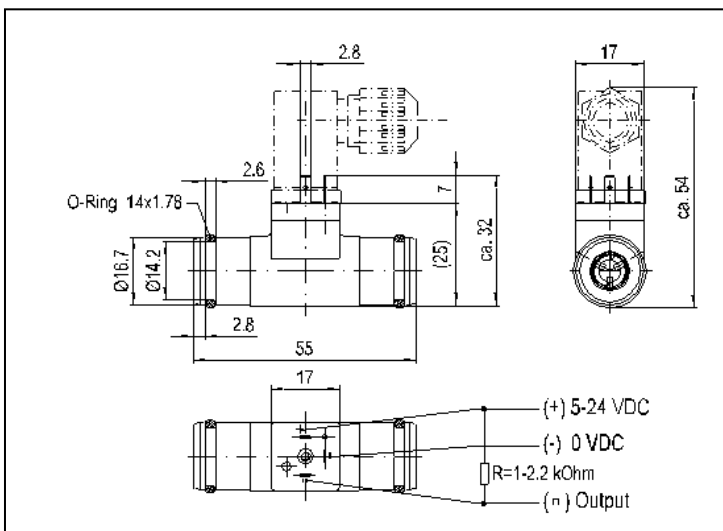

Example: Vision 2000 with O-Ring

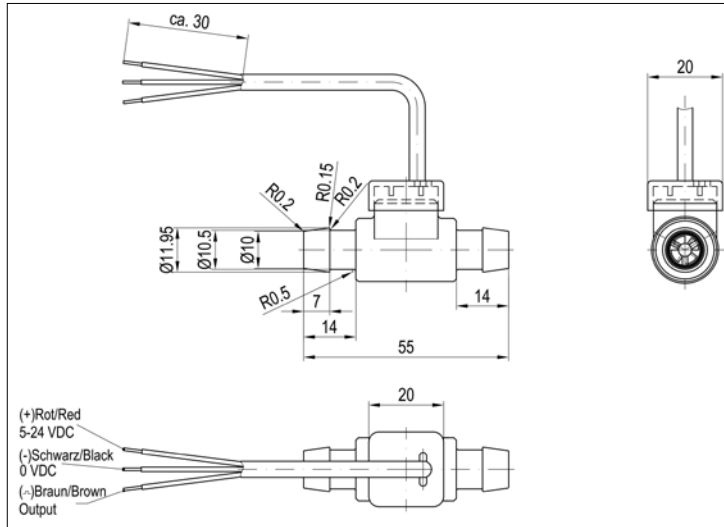

Example Vision 2000 with round cable 3 x AWG 24 and hose nipple

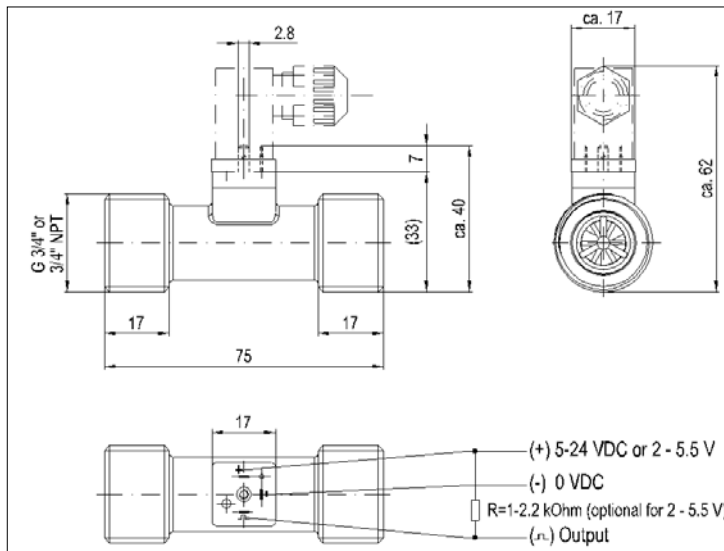

Example Vision 3000 with DIN plug